

A strong character for heavy-duty operations

FENDT 900 VARIO^{TMS}

916 • 920 • 924 • 926 • 930

VARIO^{TMS}



FENDT

SUCCESSFUL HIGH HORSEPOWER TRACTORS WITH VARIO™

The 900 Vario's success was not created overnight, but has grown continually since its introduction in 1996. This success is the result of unparalleled continual development focussed on maximizing utilization for customers.

Vario™ – the newest generation of the Fendt stepless drive technology now offers even simpler operation and even better profitability. That gives you the decisive edge on productivity along with first-class driving comfort.

For the toughest operating conditions, Fendt presents in a new power class, the 930 Vario™ with 310 HP – the strongest Fendt ever built.

Over 35000 customers have chosen Fendt Vario so far. The advantages and benefits of the Vario technology have been confirmed in daily in-field operation.*

We offer you leading-edge technology and long-term experience.

** as at November 2003*





Contents

<i>Successful high horsepower tractors</i>	2
<i>Comfort for a long work day</i>	4 - 5
<i>Variotronic – your best worker</i>	6 - 7
<i>A new way to drive – Vario driving with TMS</i>	8 - 9
<i>The Varioterminial – 6 keys, 3 controls</i>	10 - 11
<i>More productivity through implement memory</i>	12
<i>Headland Management Variotronic™</i>	13
<i>Control console for all functions</i>	14 - 15
<i>900 Vario cutaway diagram</i>	16 - 17
<i>Perfect drive unit</i>	18 - 19
<i>Vario – simple and robust</i>	20 - 21
<i>Comfort and mobility</i>	22 - 23
<i>Perfectly planned hydraulic system</i>	24 - 25
<i>Earn more with a Fendt Vario</i>	26
<i>Optional: Swath guidance system Auto-Guide</i>	27
<i>Superior productivity</i>	28
<i>Fendt service and support</i>	29
<i>Technical specifications and standard equipment</i>	30 - 31

Max. power
ECE R 24
HP/kW

916 Vario ^{TMS}	198/146
920 Vario ^{TMS}	220/162
924 Vario ^{TMS}	253/186
926 Vario ^{TMS}	286/210
930 Vario ^{TMS}	310/228

COMFORT FOR A LONG WORK DAY

The 900 Vario^{TMS} is ideal in terms of ergonomics and functionality, which are realized in every last detail. The different functions can be operated comfortably and are easy enough to understand immediately. Working in this relaxed manner, the driver can take advantage of the full potential of the Vario throughout a long working day.

A major concern for the Fendt driver is maintaining condition and fitness. Intelligent Fendt control technology supports these needs. Choose your work place for the next years very carefully! Comfort has become an important factor in overall profitability.

The original Fendt super comfort seat: standard specification for more relaxation and enhanced well-being.

The original Fendt Super Comfort Seat offers perfect adaptation to different sizes through an integrated backrest extension, legroom adjustment and seat tilt adjustment. This seat presents a new dimension of comfort with its air suspension, automatic weight adjustment and low-frequency suspension. Other health-benefiting standard features include pneumatic adjustment of the lumbar support, an activated carbon layer in the seat, height adjustable arm rests and the seat heating. Your health is important to us.





Better overview, ingenious controls, utmost comfort

THE VARIOTRONIC – YOUR BEST WORKER

Welcome to the Variotronic World. You work many hours on a 900 Vario™S – that is why operating and driving comfort have the highest priority. With its three elements – a joystick, monitor and control console – the Variotronic not only ensures extraordinary working comfort, but also unparalleled productivity.

With the new Variotronic™ you can recall previously stored, optimized working processes with a touch of a key – again and again. For you this means ingeniously simple handling – not just during the test drive. Moreover, you will receive full benefits in profitability and productivity during in-field operation.

Joystick: everything under control with one hand



Variotronic Terminal: information and command centre



Information and command centre: well-organized control units





A NEW WAY TO DRIVE VARIO DRIVING WITH TMS

Driving a tractor is certainly more than just sitting in it and driving away. You know that most of all. There are different conditions to consider for every operation you carry out with your tractor. That is the reason why you should evaluate an operating concept based on specific operations. This was the practical background which was the basis for the development of the Vario operating concept with the Tractor Management System Vario^{TMS}. Compared to operating concepts on other tractors with stepless transmission, the Tractor Management System Vario^{TMS} Vario TMS from Fendt provides very convincing concrete benefits. It allows you to carry out your work more comfortably and easily. Beginners find their way around quickly and easily, and the Vario^{TMS} concept offers great potential for professionals. Whether you are a beginner or pro – Vario^{TMS} allows you to do your work more profitably.

Vario^{TMS} – typical Fendt

accelerate

decelerate

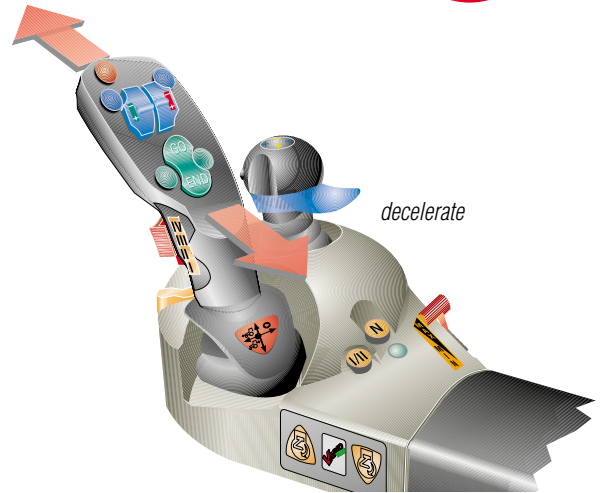

Driving with the joystick

The ingenious control which allows you can carry out all functions using only your right hand, without having to change grips. You can accelerate, decelerate and reverse as well as activate the Tempomat with only a small movement of the joystick. You can operate all other functions, from the easy-to-use PTO automatic mode to the headland management system, with the ergonomically friendly multi-function buttons.

TRACTOR MANAGEMENT SYSTEM

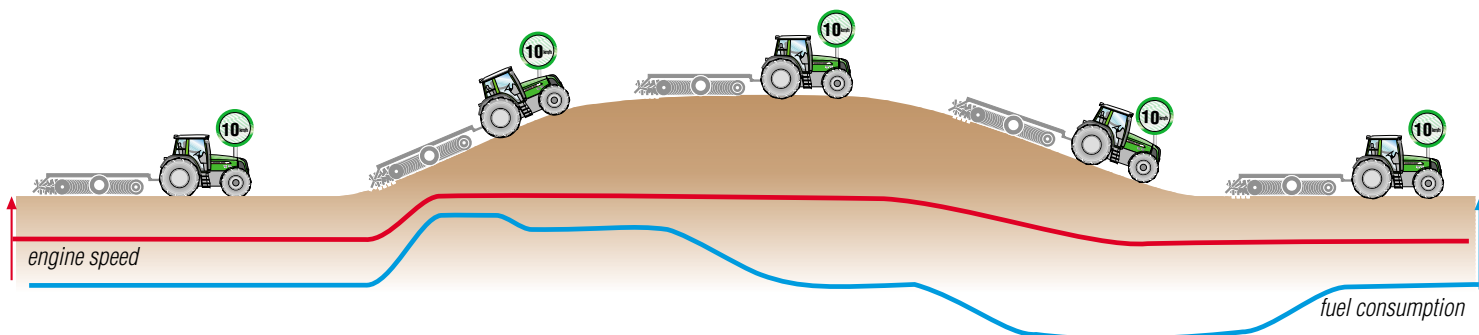

When the TMS (Tractor Management System) is activated, the tractor electronics control the engine and transmission. This significantly increases operating comfort for the driver. The driver only needs to set the desired speed; the TMS controls the rest. In the graphic above, one can recognize that the tractor drives on level ground at a reduced

engine speed. On the slope, the load increases, so the TMS increases the engine speed. As soon as the load decreases (on level ground or downhill) the quantity of fuel injected is reduced. This maintains an economical driving style since TMS drives the tractor at the lowest engine speed possible.

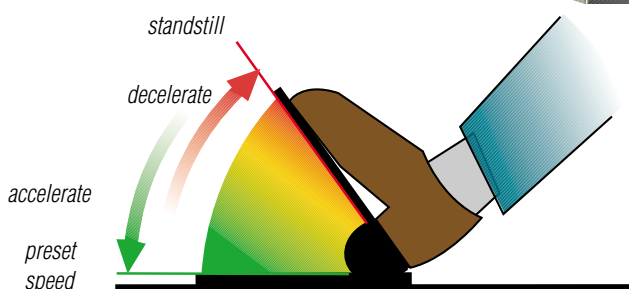
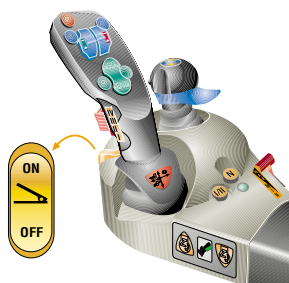
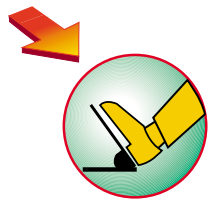

Driving pedal mode

Set the direction you would like to drive with your left hand, then all that is needed to start the tractor is to press the driving pedal. In the driving pedal mode, only the right foot is required to drive the tractor – similar to a car with an automatic transmission. The further the pedal is pressed down, the faster the tractor goes. The sliding control on the armrest sets the maximum speed that is attained when the pedal is pressed all the way down. If you release the pressure on the pedal, the 900 Vario^{TMS} decelerates.

NEW: For an additional engine braking effect, the driver can also take over control of the TMS in the driving pedal mode and reduce the transmission ratio manually.

NEW: The switch on the steering column adjustment lever has three functions:

1. Changing directions while driving.
2. Setting travel direction in the driving pedal mode.
3. Stop and go function with active parking function:

If the switch is pressed while moving, the tractor decelerates to a standstill. The tractor only starts to drive again when the switch has been released. This function provides even more comfort for all work which requires frequent short stops.



VARIO OPERATION – EASY AS EVER

Transmission control per joystick and engine control per foot pedal or hand throttle

Driving forward

Push the joystick forward; the Vario accelerates forward from standstill.

Accelerate forward

Not fast enough? Then push the joystick forward a bit longer, until you have reached the desired speed.

Decelerate

If you are going too fast, pull the joystick back and the Vario 900 brakes the engine and transmission.

Reverse

Pull the joystick back and the Vario reverses from standstill. Faster or slower reverse speeds function in the same way as for forward travel.

Rapid or slow acceleration

How rapidly or slowly you accelerate or decelerate with the transmission is determined by which of the four pre-set acceleration rates you select with the thumb control.

Automatic forward/reverse

Giving the joystick a quick tap to the left is all that is necessary to change driving direction from forward to reverse or vice versa. The Vario decelerates to a standstill by itself and then accelerates efficiently, without jerking, in the opposite direction.

Tempomat cruise control

The Tempomat holds the tractor at a constant pre-set speed. All that is required to activate it is to give the joystick a quick tap to the right.

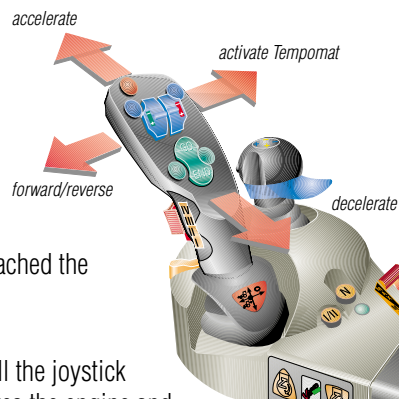



THE VARIOTERMINAL – 6 KEYS, 3 CONTROLS, IT COULDN'T BE EASIER

top agrar 11/2003
 «Once one has become familiar with the Vario-terminal, one can work very well with it. In any case, this solution makes more sense than having many individual small displays in different places and it provides a better overview.»

With the Varioterminal, Fendt has redefined operating and control comfort. Combining setting and control elements into one functional unit not only makes simple applications even easier, but also aids the experienced driver during complex tasks. This high degree of customization is a benefit to every driver. Ask any Vario driver.



NEW: last function status – with a single touch of a key
 All the functions which were used last are reactivated with the touch of a key. That guarantees full operational readiness from the very first second.

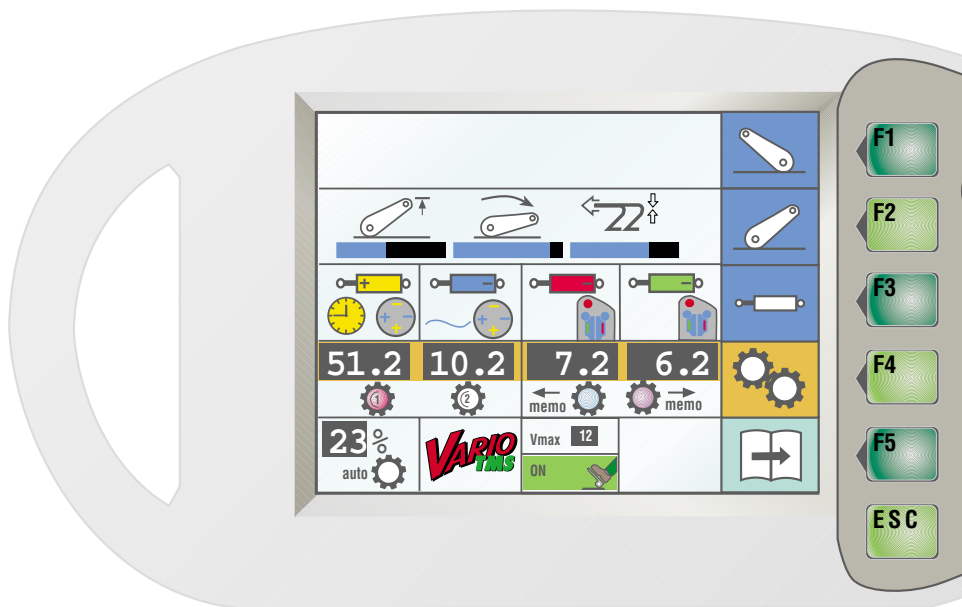

Function	Settings
F1 Front power lift (*)	lift height, lift speed lowering speed
F2 Rear power lift	lift height, lowering speed position/draft mixed control
F3 Auxiliary control units	flow rates time functions
F4 Transmission	Tempomat pre-set optimization of transmission
F5 Change menus	change to Main Menu II

* optional

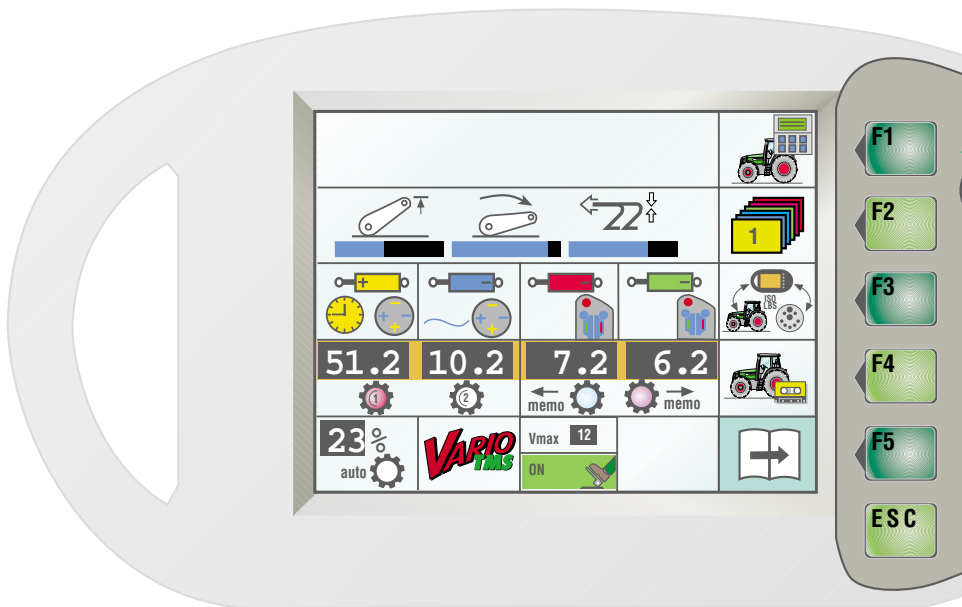

Function	Settings
F1 On-board computer	field-specific recording for 4 fields
F2 Implement memory	storage of 4 implement-specific tractor settings
F3 Implement control	controls for implements with BUS capability
F4 Variotronic™	Headland Management System
F5 Change menus	change to Main Menu I

VALUABLE FUNCTIONS THAT MAKE THE FENDT DIFFERENCE

Fuel consumption display

standard



A precise overview of the fuel economy of your 900 Vario™. With the standard specification fuel consumption measuring function, you can monitor how much fuel your tractor actually uses with $\pm 3\%$ precision. Moreover, the absolute fuel consumption as well as area or time-specific consumption can also be calculated and saved.

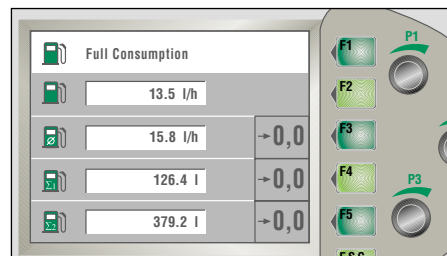

On-board computer

standard



Your performance recorded in black and white. Everybody is talking about documentation. The on-board computer in the Varioterminale records all of the most important parameters – such as distance travelled, area coverage, time and external impulses – easily and exactly.

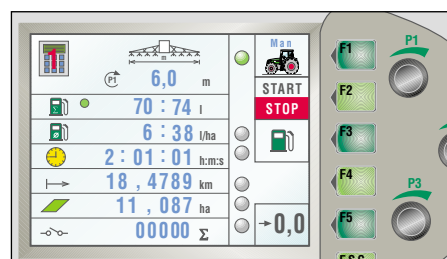

Variotronic Implement Control

standard

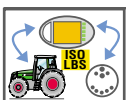

For the best tractor, implements from the right manufacturer. Whether manure spreader, baler, plough or loading wagon, with the Variotronic implement control you can control all implements which have ISO/BUS or LBS+-capability with the Variotronic and the joystick.

Advantages of the Fendt Implement Control:

- optimized ergonomics
- one terminal for all implements
- always the same simple control logic
- simple implement changes
- can be updated at any time

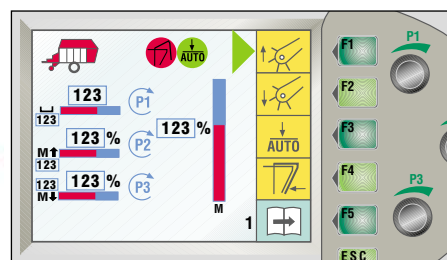

Variotronic camera

optional



Control, safety and a great overview – the Variotronic camera, which can be positioned freely, is the right solution for all applications. Its wide-angle picture is super sharp and always gives you a perfect overview.





Store implement settings for increased productivity

VARIOTRONIC IMPLEMENT MEMORY OPTIMIZE ONCE, PROFIT AGAIN AND AGAIN

top agrar 11/2003

«The Headland Management System offers numerous possibilities.»

To compare different tractors, it is essential to investigate the use or the consumption of production factors (e.g. working time, fuel, ...) per hectare area coverage. Thanks to Variotronic Implement Memory you can work at full performance during every operation, starting from the very first second. All tractor settings are stored to memory and recalled with a simple touch of a key. That allows you to achieve more. Give it a try!

Vario Implement Memory:
NEW: Even easier
NEW: Even faster
NEW: Even more productive

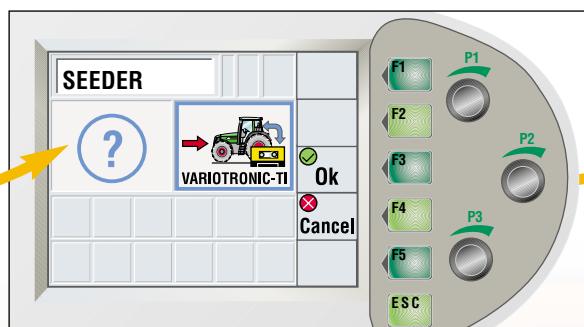
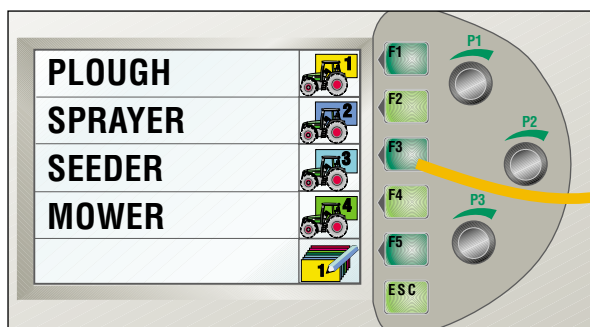

1. All tractor settings (power lift, auxiliary valves, transmission, engine) are optimized once and stored.

2. NEW: tractor settings combined with the Headland Management System..



VARIOTRONIC^{TI} – THE HEADLAND MANAGEMENT SYSTEM FOR WINNERS

3. A touch of a button on the joystick triggers the automatic procedure at the headland

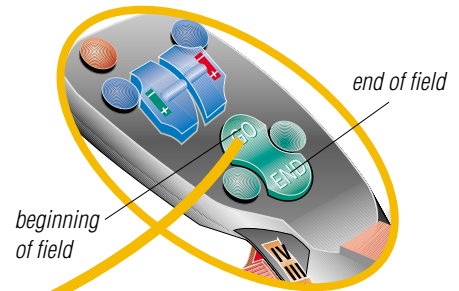
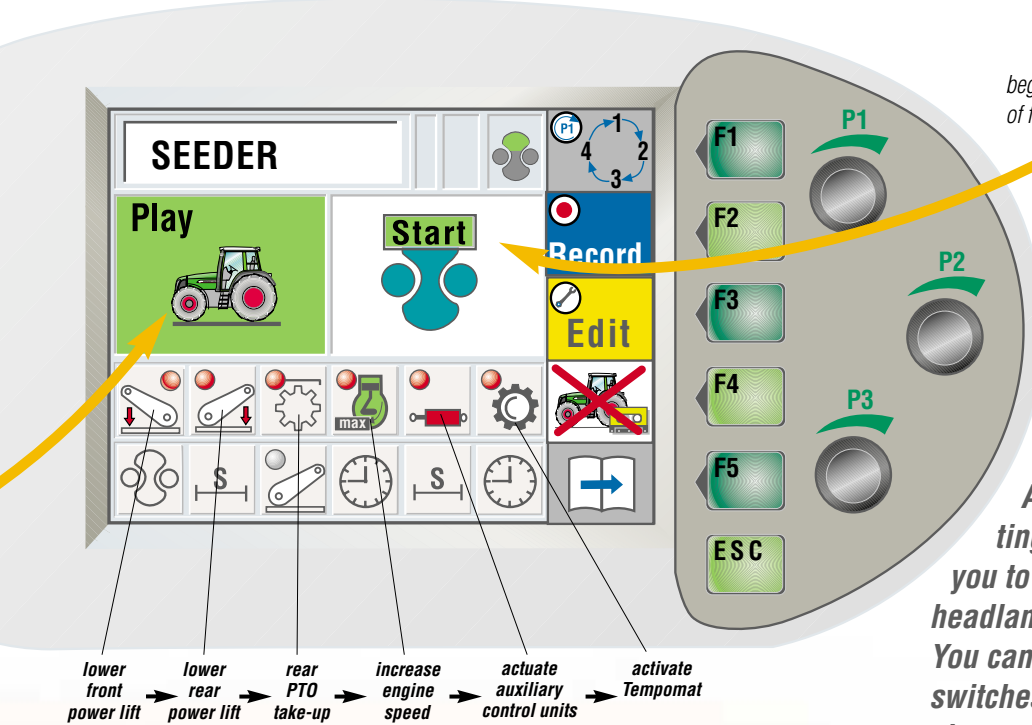

Ingenious ergonomics
joystick with button controls

While others are still at the headland, busy with countless hand movements, you are already back at work in the furrow with your 900 Vario.

After optimizing and storing the settings once, the Variotronic TI allows you to profit every time you are at the headlands.

You can trigger up to 13 functions with the switches on the joystick without having to change hand grips. You will be impressed, especially on long working days.

Benefits:

- Time saved at the headlands
- Reduced idle time and therefore increased area coverage
- Long-lasting driver relief on long working days
- High degree of customization possible
- Simple, logical set-up
- 16 sequences with up to 13 functions can be stored for 4 implements
- Unparalleled ergonomics

The new Variotronic^{TI} –
for a measurable increase in productivity





CONTROL CONSOLE FOR ALL FUNCTIONS

The electrohydraulic power lift control combines maximum work quality with superb operating comfort, which reduces stress on the driver. Front and rear-mounted implements can be controlled conveniently with the buttons on the joystick. Automatic functions are integrated. The newest EPC generation is incorporated in the tractor diagnostics.

Maximum working quality during working combinations through front position control and rear EPC.

For many years, features such as operator comfort, an extensive range of controls and the logical layout of the EPC have become indispensable to the Fendt-driver in his daily routine.

Plough, seed drill or chopper are electronically controlled with sensitive accuracy in the set working position and without the constant use of manual controls. All front-mounted implements can be controlled conveniently and precisely in the position control mode of the new controllable front power lift.

EPC via the Vario terminal

Lift height, lowering speed and position-draft mixed control are steplessly

and accurately controlled with the finely adjustable rotary buttons in the Varioterminal. The selected values can be read off the indicator bars.

EPC for added value and less stress on the driver

This new EPC generation is incorporated in the tractor diagnostic system. It automatically monitors itself through digital signal processing and ensures operational reliability. The integrated shock load stabilizer works like an electronically controlled shock absorber. Even with rear-mounted implements, the driver can drive over paved and unpaved roads quietly, quickly and with a high degree of driving safety.

Unique automatic joystick control for PTO's and lifting implements

Implement lift and PTO's can be controlled conveniently with the rocker switches and buttons on the joystick. The automatic mode allows the PTO's to be engaged and disengaged automatically when the implement is lifted and lowered.

Practical PTO technology

The PTO's can be controlled easily with the push buttons on the control console and the rear PTO can also be controlled conveniently from outside. The PTO automatic mode allows for even better productivity.

AWD and diff. locking control or automatic mode

control suspension Tempomat

front PTO/front power lift control

The two-speed PTO

The Vario 900, designed to be a system tractor, features two PTO speeds at the rear (750/1000 rpm). The 750 rpm economy PTO allows fuel-saving, stress-reduced operating at lower engine speeds.

1000 rpm front PTO (optional)

The front PTO is driven directly from the engine with no loss of power.

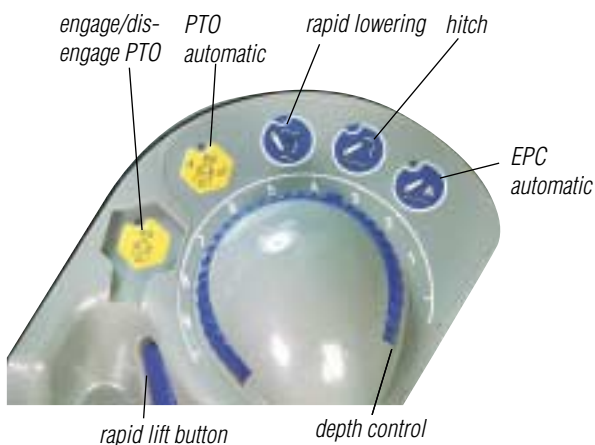

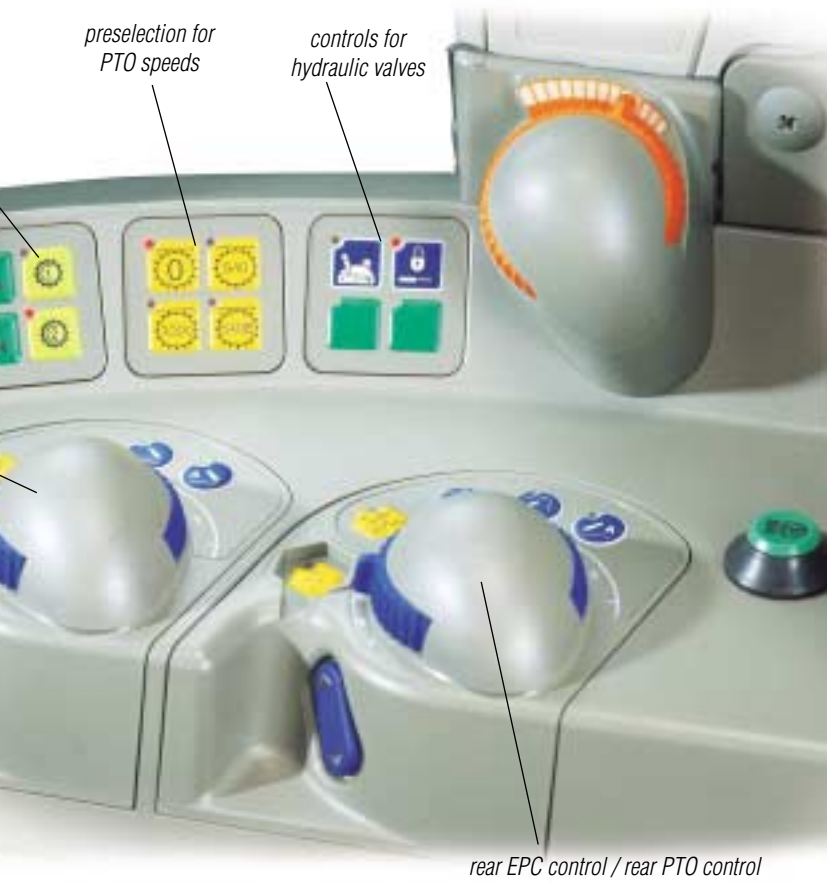

Symbol	Function	In-field advantage
	AWD permanently engaged	<ul style="list-style-type: none"> • full transfer of power
	AWD automatic AWD turns off if: <ul style="list-style-type: none"> • steering angle > 25° • speed > 15 km/h 	<ul style="list-style-type: none"> • driver relief • soil protection • full manoeuvrability • less tyre wear
 	permanent 100% disc differential locking differential lock automatic turns off if: <ul style="list-style-type: none"> • speed > 15 km/h • steering angle > 15° • brakes are operated 	<ul style="list-style-type: none"> • full transfer of power even under severe conditions • driver relief • easy manoeuvring • greater transfer of tractive power
	PTO speeds: 750/1000 rpm or 540/1000 rpm	<ul style="list-style-type: none"> • simple and comfortable PTO operation

Automatic PTO take-up control saves operating costs

The Vario 900 offers a load dependent PTO take-up. Take-up of the drive is sensitively controlled and monitored by the electronic system according to the power requirement of the implement. This benefits the life of all PTO components thereby reducing operating costs.

Intelligent AWD and differential locking technology

Reduces stress on the driver and adapts itself perfectly to different operating conditions. Depending on the selected stage, AWD and differential locks are automatically reactivated or disengaged subject to either steering angle or speed. Result: optimum transfer of tractive power during

heavy-duty operations (the AWD and differential locks can be engaged and disengaged under load with a button on the control console).



FENDT – SELF-CONFIDENT STRENGTH

Fendt 900 Vario™: the new generation of high horsepower tractors from 198 to 310 HP. These new 900 Varios are not only distinguished by a new design, but also by the high performance technology found under their bonnet. Intelligent state of the art technology for self-confident strength.

- 1** Front driving axle, 50° steering angle
- 2** Hydropneumatic front axle suspension with levelling control and 2 cylinders, can be locked
- 3** Front power lift
- 4** Front PTO
- 5** Planetary final drive
- 6** Ladeluftkühlung
- 6** Intercooler
- 7** Modular compact cooling system
- 8** 7-litre Man engine with electronic engine control
- 9** Air filter with Strata® precleaner and ejector
- 10** Hydr. pump and hydr. motor
- 11** Planetary gear set
- 12** Enclosed AWD
- 13** 530-litre fuel tank
- 14** Nitrogen pressure accumulator (suspension)
- 15** Gas strut shock absorber for cab cushioning
- 16** Rear wheel disc brake
- 17** Front wheel disc brake
- 18** Planetary axle
- 19** tiltable comfort cab
- 20** Additional lights

- 21** Air-sprung comfort seat with mechanical lumbar supports, front-to-rear suspension and mechanical rotary adjustment
- 22** Joystick for stepless driving as well as to control the hydraulics and PTO as well as TMS functions
- 23** Varioterminal to adjust the driving functions, the hydraulics and the electric valves
- 24** Variotronic™ headland management

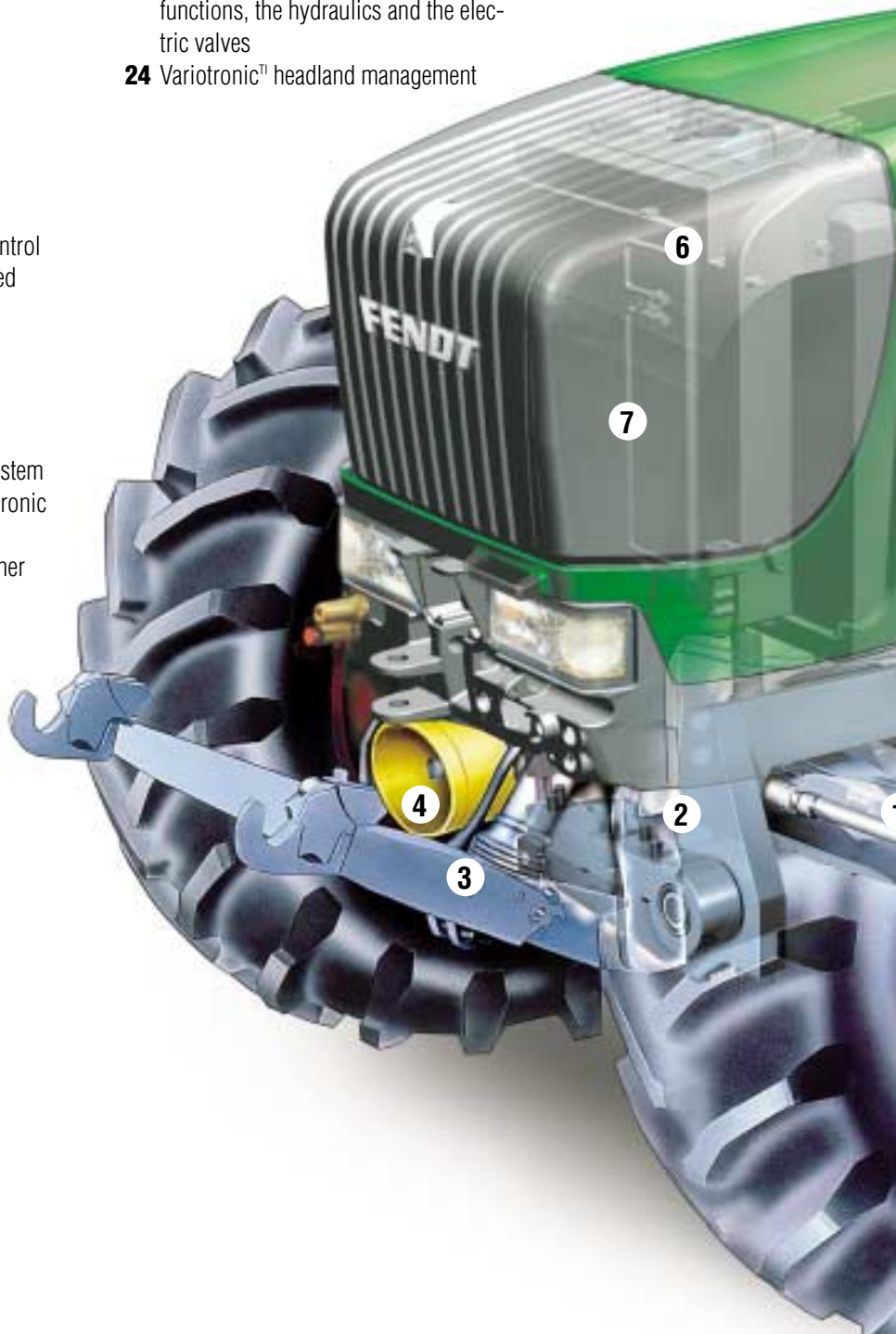





A PERFECT DRIVE UNIT WITH IMPRESSIVE PROFITABILITY

top agrar 11/2003

«nevertheless, the tractor was the most economical.»

The MAN engine and Vario transmission form a perfect unit since the stepless drive ensures that the engine always runs in the optimum range. These renowned 7-litre engines combine the latest electronically controlled charging and injection technology with top efficiency, excellent fuel economy and extremely quiet running.

The advantages

- Superb pulling power created by 40% torque rise and constant power output
- Up to 10% extra power (916)
- Quick off the mark: from 0 to 50 kph in 10 secs.
- Extremely economical. Optimum consumption only 194 g/kWh
- Quiet and smooth running
- Low running costs: oil changes required only every 500 operating hours
- Exhaust emissions that fulfill future emission standards
- Easy starting even at low temperatures
- 530 l fuel tank

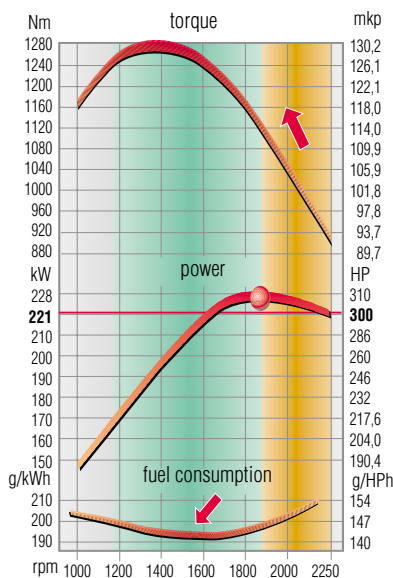

930 Vario
35% torque rise
10 HP extra power

Turbocharger and intercooler

The turbocharger which has been adapted to the higher power output and the efficient intercooler ensure maximum power availability.



New: air filter concept

The engine intake, which is located under the engine bonnet in the area with the least dust, and a new air filter system with a highly efficient precleaning system, ensure interruption-free continuous operation, even under extreme conditions.

Rugged high performance MAN engine

The latest electronic Bosch VP 44 high pressure injection pumps ensure exceptionally fuel economy consumption and a continuous 35 % torque increase. That provides impressive pulling power.



- *Visco fan*

- *replaceable cylinder liners*

- *cross-flow cylinder head*

- *intercooler*

- *electronic high pressure injection pump*

- *needle movement sensor*

- *7-bearing crankschaft for quiet running*

New: Electronic engine control EEC

Electronic engine control is a further step towards optimizing combustion. The engine is not optimized for one particular point, but is continuously being adapted to the current vehicle conditions. The result is improved response, a further reduction in emissions as well as concrete improvements in power output and fuel economy. At the same time, the EEC brings significant improvements in operating comfort through an electronic hand throttle. With it you can set the upper and lower stops for often repeated settings.

New: cooling system

The cooling system was completely redesigned for the 900 Vario™ range. Its larger intake areas, oil-cooled pistons and new cooling air layout are adapted perfectly to the new high output models.

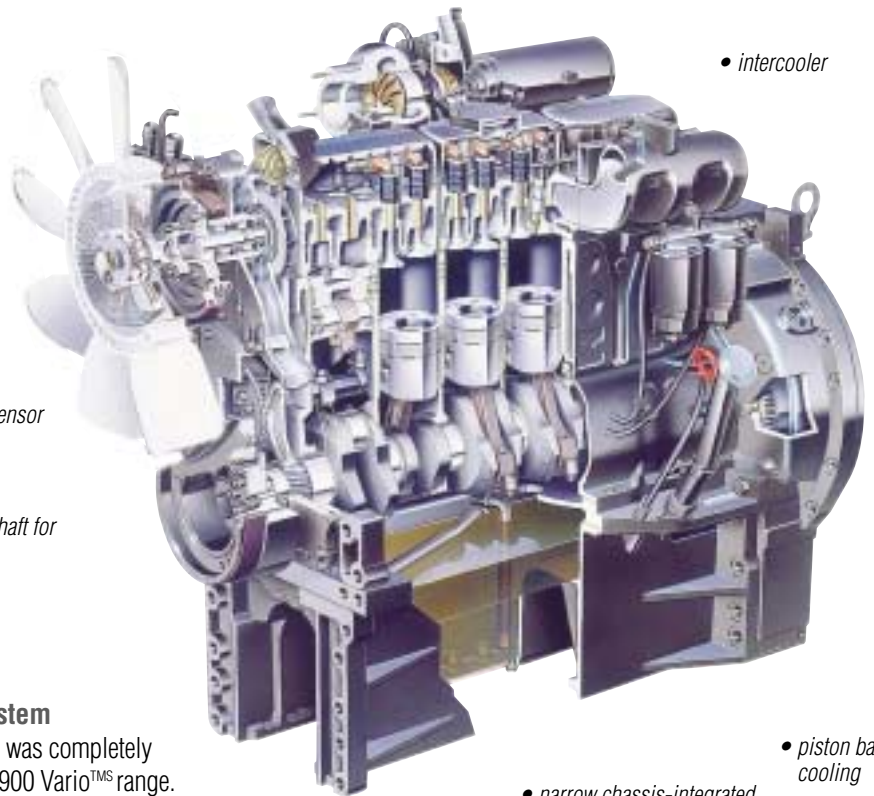

- *piston base cooling*

- *narrow chassis-integrated oil sump for optimum manoeuvrability*

- *noise-reduced engine*





VARIO – SIMPLE AND ROBUST

*Vario means that you can truly change your driving speed steplessly. No more gear shifting. Unlike pure hydrostatic drives, the Vario drive lets you work with a very high degree of efficiency – as high as that of a power shift transmission. The secret lies in power splitting, an intelligent combination of mechanics and hydrostatics. Independent tests have repeatedly confirmed the constant high efficiency level of the Fendt Vario concept.**

Power splitting

The engine output is split into a mechanical and a hydrostatic section by a planetary gear. Only the hydraulic branch controls the system. Both power trains are consolidated in the collecting shaft.

Hydraulic transmission section

The hydraulic drive unit consists of a hydraulic pump and two hydraulic motors with a unique displacement

angle of 45 degrees. Depending on the position of the in-unison controlled hydrostatic units (pump and motors), the driving speed is regulated steplessly.

Mechanical transmission section

The mechanical branch also begins at the planetary gear and runs over the mechanical gear connections and the travel range selector to the collecting shaft.

Starting with the Vario

When starting, the major part of the engine output flows over the hydrostatic branch. The efficient interplay between the mechanical and hydrostatic sections is reflected in high acceleration values. The higher the speed of the vehicle, the more the tractive power shifts to the mechanical branch.

Reverse travel

Changing travel direction is sensationally easy with the Fendt Vario concept: the hydraulic pump is just swung out in the opposite direction.

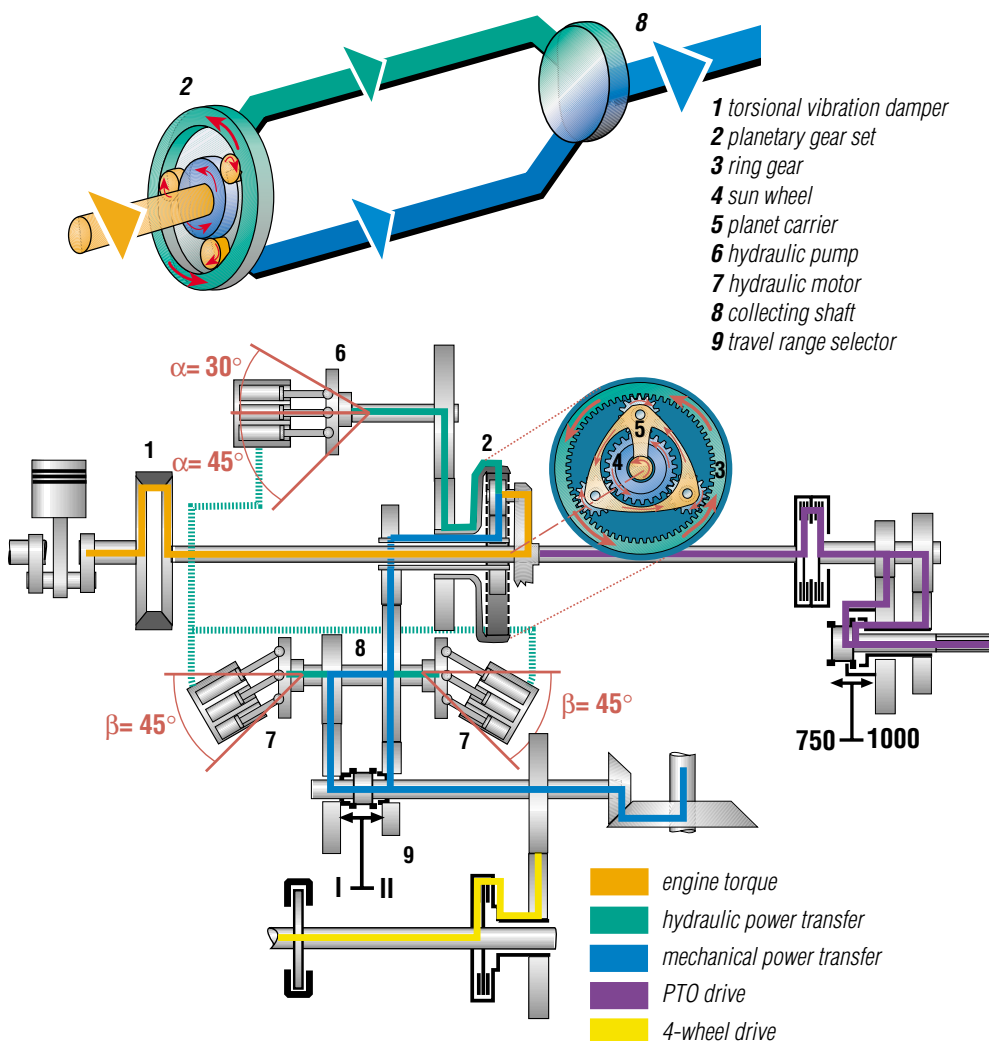

*Nürtingen University, DLG Testing Station, Farmers Weekly March 2001, Boerderij 21/2001



No more power draining mechanical forward/reverse shifting.

The secret of the Fendt Vario Drive

Since the Vario drive uses large hydrostatic units, the complete travel speed range from 20 m/h to 50 km/h can be covered by just 2 travel speeds. This, together with the exclusive 45 degree displacement angle, bring new dimensions in efficiency. At the same time, this concept allows the controls to be simplified, making them failsafe.

Advantages:

- **uncomplicated, robust design**
- **top efficiency**
- **only 2 travel ranges from 0.02 kph to 50 kph due to hydrostats with 45° angling**
- **reduced noise level due to flexible drive block bearing support**
- **optimised oil supply for long life and top-efficiency**
- **easy servicing**

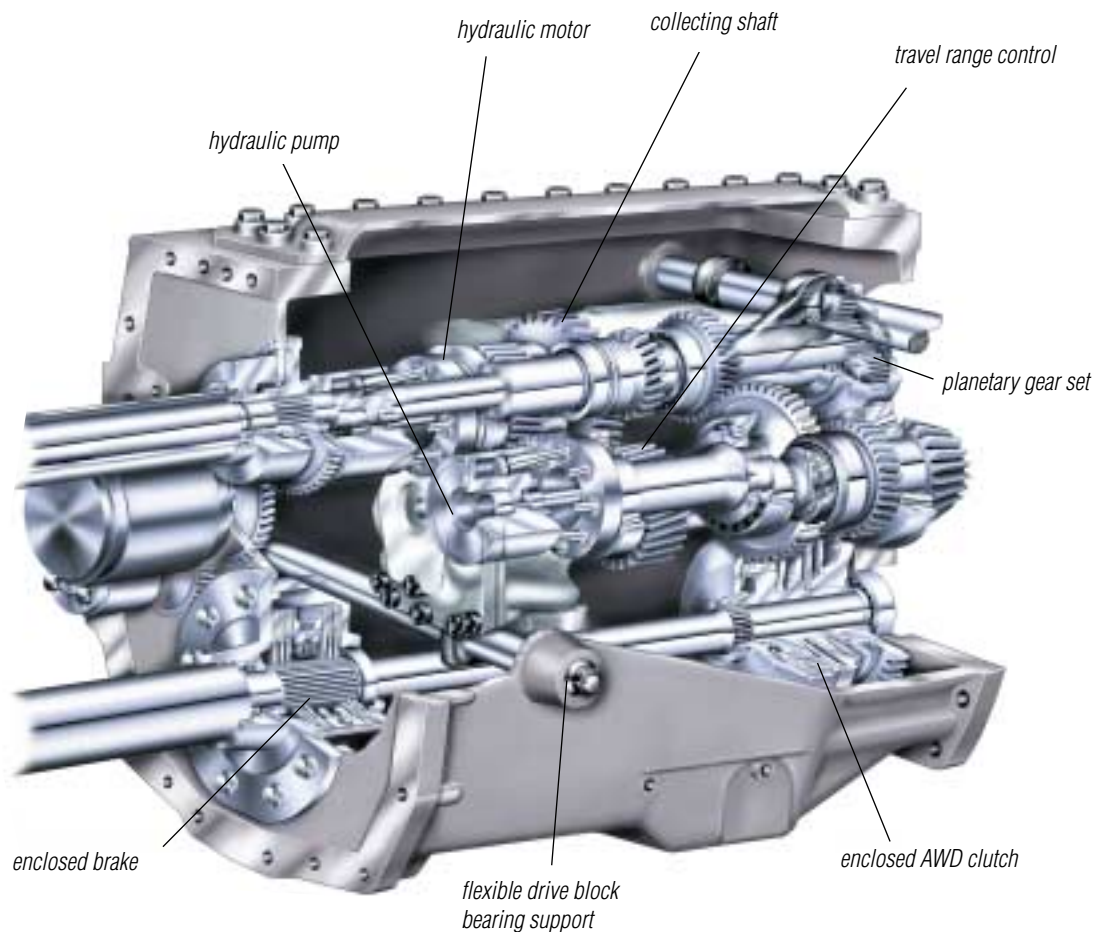

**Quiet drive through flexible drive block bearing support
Optimized oil supply for long life**

The entire Vario drive block is supported by rubber elements designed to neutralize noise. Severe acoustic parameters also apply to the housing.

The Vario transmission's total oil supply is 65 litres. All supply pipes lie fully protected inside the housing.



You accomplish more in the same amount of time

top agrar 11/2003

«It was the only one in this power class that has 50 kph and a stepless drive. The tractor attains its top speed at reduced engine speed and therefore also saves fuel. Its driving comfort is comparable to commercial vehicles.»

COMFORT AND MOBILITY THANKS TO SUSPENSION AND 50 KPH SPEED

With its innovative chassis technology, the new Fendt 900 Vario™ offers mobility, driving safety and driving comfort on the exceptionally high level of commercial vehicles. Fendt has long-term experience with the series production of suspension systems. That helps to keep you fit and increases productivity. Fendt solutions secure the leading edge in technology that bring you ahead – day after day and year after year.



Dynamic and economical:
the 900 Vario during haulage at
50 kph* and 1800 rpm

Driving comfort on commercial vehicle level:

The result of the intelligent interaction of three systems:

1. Front axle suspension with levelling control
2. Cab suspension
3. Shock load stabilizing

Front axle suspension

The swing axle, centrally located in the swing arm, detects uneven surfaces and transmits these findings to the swing arm. Three nitrogen reservoirs reduce shock loads by up to 60%. The tractor body remains still. The automatic levelling control allows for a constant, high degree of driving comfort, even with high payloads. The front axle suspension can also be locked to master particular work situations, e.g. for precise depth control.

NEW: Pneumatic cab suspension

Oil-filled hydraulic supports in the front stabilize the cab in the front-to-rear direction and absorb noise. The new pneumatic cab suspension features air springs that support the load at the rear. These feature automatic levelling, which automatically adapts the suspension to varying loads. Setting different suspension levels is no longer necessary. Your benefit: advanced, permanently relaxed driving comfort in the field and on the road.

Speed-dependent shock load stabilizing system

This system acts like a hydraulic shock absorber. Activation can be controlled via the Varioterminal. Even with a rear-mounted implement, the



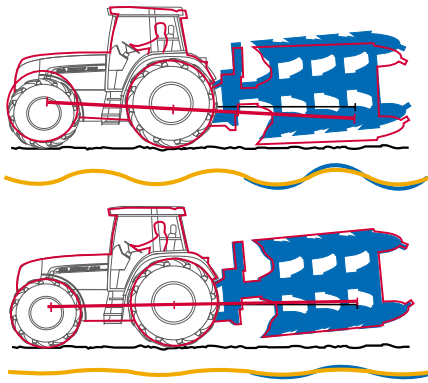

operator enjoys a comfortable and safe ride without a reduction in speed, and most importantly, without stressful bounce, on the road as well as the field track.

Top-efficiency lifetime braking system

The four-wheel braking system is virtually maintenance-free and ensures superb safety in road traffic at 50 kph*. It is based on two integrated multi-disc brakes for the rear wheels fitted with sinter linings having a high thermal load capacity, as well as a disc clutch on the cardan shaft for the front wheels.



Front axle and cab suspension maintain driver fitness and efficiency

The swing axle (1) detects uneven surfaces and transmits these findings to the hydraulic cylinder (2) on the pivoted axle carrier (3) forcing the plunger of the cylinder either upwards or downwards. The displaced oil immediately activates the nitrogen reservoirs (4) which absorb all shocks. Hydro supports (5) at the front together with helical springs (6) and shock absorbers (7) at the rear, control the movement of the cab in the front-to-rear direction and eliminate vibrations and shock loads emanating from the body of the tractor. A Panhard rod (8) acting as a stabilizer controls transverse movements. Result: a quiet, relaxed working atmosphere without bounce.



* the top speed of 50 kph is not permitted in all countries

PERFECTLY PLANNED HYDRAULIC SYSTEM

The Variotronic opens a whole new dimension in control comfort. All the hydraulic functions are integrated into it, simply and logically, so that the driver can react quickly and safely. You will enjoy taking control with the joystick, crossgate lever and control terminal. The Vario terminal allows you to attain the utmost of comfort and profitability easily.

Powerful and economical: the load-sensing system

At the heart of the system is a powerful axial-piston pump, which supplies the steering system, power lift and up to 5 auxiliary control units with up to 117 l of oil at 200 bar. That provides the rear hydraulics with a lift capacity of 10,173 kp and 5150 kp for the front hydraulics. Long service intervals and separate oil supplies for the hydraulics and transmission ensure low operating costs.

controls for spool valves

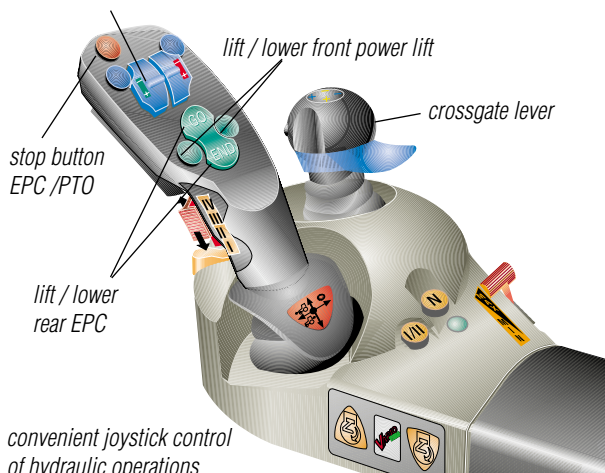

convenient joystick control of hydraulic operations



NEW: Optional with double connect-under-pressure couplings

The new connection ensures simple and leak-free connections – whether the pressure is on the tractor and/or implement side.

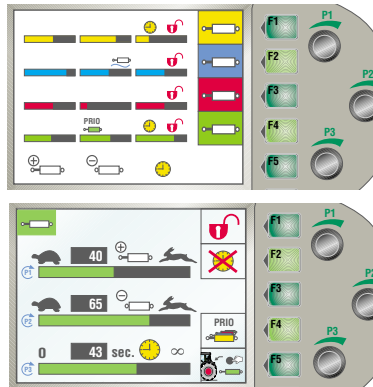

Electrical valves: premium class work and control comfort

The joystick and the newly designed crossgate lever control the electrical apportioning valves. On the 900 Vario these are all double-acting control units that can also be used in a single-acting capacity and feature a floating position. The first two apportioning valves are located on the convenient crossgate lever. For the other valves on the joystick, just a quick touch of the rocker switch is all it takes to guarantee that all hydraulic tasks are executed with the utmost accuracy. The control functions can easily be toggled from the joystick to the crossgate lever and vice versa. In the Vario terminal, you can control the flow rates and actuation times of all the electrical apportioning valves easily with the rotary controls and the function keys.

NEW: Optional external hydraulic valve controls

Either the 3rd or 4th hydraulic control unit can be operated externally with the pushbuttons on the rear light bracket. When using a hydraulic top link you can couple and uncouple your implements ever faster. Or, for example, you can control the hydraulic slider on your slurry wagon without having to climb up.



Advantages:

- prioritization of auxiliary control units allows rapid response and short lifting times even at low engine speeds
- environmentally friendly through separate hydraulic oil supply
- low servicing costs through long service intervals (hydraulic oil: 2000 hrs.)
- high max. delivery capacity through state of the art axial piston pump
- can be expanded with up to 5 auxiliary control units and a separate load-sensing connection
- down-force rear and front hydraulics
- powerful power lifts with lift capacities up to 10,173 kp at the rear and 5150 kp at the front
- comfortable implement change through external push buttons (lift, lower) for front and rear power lift

THE VARIO 900 AS A SELF-PROPELLED HARVESTER

With the stepless Vario transmission and the integrated reverse-travel facility (optional), the Favorit 900 turns into an economic 310 HP self-propelled harvester. Applications range from mowing grass and chopping maize to recultivation work and winter maintenance operations. Visibility in reverse operations is fantastic. Versatility and a higher degree of utilization make the 900 range tractor a very attractive alternative for agricultural contractors.

Top-efficiency harvester with superb visibility

When cutting grass or chopping maize, for instance, full engine power is available because the speed is steplessly and automatically adapted to the crop density. The driver enjoys superb visual monitoring of the crop to be harvested.

Superior profitability

Unlike conventional self-propelled harvesters and high-performance tractors from other companies, the Favorit 900 has the versatility to be used throughout the year, thus achieving greater utilization. That reduces costs per operating hour and guarantees superior profitability.

Perfect speed adaptation for special operations – up to 20 meters/h

For heavy-duty PTO work in road building and maintenance, for recultivation work or for winter service operations, slow working speeds are especially important. With the Vario, the driver can adapt to the particular operation by adjusting speed steplessly with the joystick – from 50 kph to 20 meters/h. This makes the Vario a top-performance specialist.

Advantages:

- **Top efficiency universal self-propelled harvester**
- **Vario transmission for optimum adaptation to all kinds of operating conditions**
- **Perfect visual monitoring**
- **Wide range of applications**
- **Economical alternative for agricultural contractors.**

top agrar 11/2003

«The cab is the only one which offers a full reverse travel facility and front and rear windows that can be opened completely.»



Why you accomplish more with Vario HP's

THE REASON WHY YOU EARN MORE WITH A FENDT VARIO

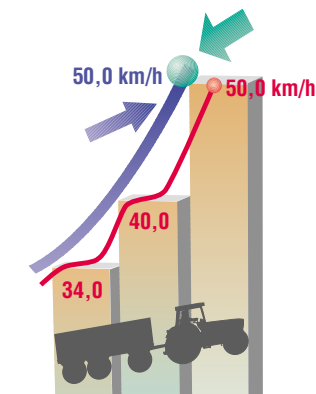

stepless to 50 kph

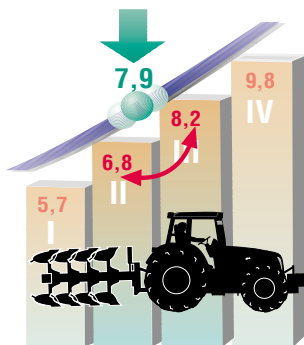

Select the exact speed you need

Fendt-Vario – better than powershift

With stepless variable speed, you can utilize power reserves that aren't even available to modern powershift transmissions. With conventional transmissions you are always one gear too high or too low because of the steps. Vario allows you to mobilize the power reserves that are hidden in between the steps. You get even more power with Fendt Vario.

The Fendt Vario is a genuine stepless drive. Fendt engineers have exhausted the potential of powersplitting persistently, using special efficiency-enhanced large-sized hydrostats. Smooth and jerk-free acceleration is possible over the entire travel speed range. The 50 kph top speed can be attained and maintained at a reduced engine speed of 1700 rpm. That provides maximum efficiency over the entire travel speed range.

Vario from Fendt – you benefit from our experience

The number of Varios, which has been manufactured and sold, speaks for itself, and shows the Vario's popularity with professional farmers and agricultural contractors. Comparison tests carried out by renowned trade journals also confirm the strengths of the Fendt technology again and again. Only Fendt offers Vario technology over the full range from 95 to 310 HP.

Vario from Fendt – not only comfortable but profitable too

Don't let yourself be misled. Vario isn't just about making operation easier (that's only impressive in the dealer's yard) – the Fendt Vario also returns your investment every day during hard-working real-life operation. Independent tests have determined an estimated increase in value through Fendt Vario of approximately 15,000 €. Vario from Fendt pays for itself.

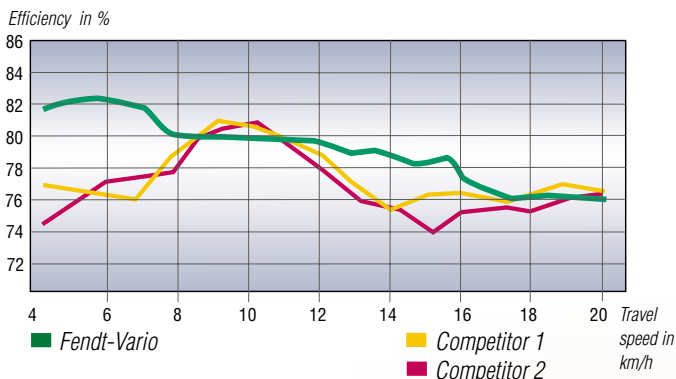

Efficiency of various stepless transmissions (according to DLG)

¹ Nürtingen University, DLG testing station
Farmers Weekly March 2001
Boerderij 21/2001
Top Agrar 12/2002



AUTO-GUIDE

SATELLITE GUIDANCE SYSTEM OPTIONAL FOR THE 900 VARIO^{TMS}

The Fendt Auto-Guide system gives you pass-to-pass accuracy the easy way – without having to use conventional marking systems. It allows you to achieve a higher degree of utilization for your tractor and implements. That is a significant increase in productivity, which also means an increase in profit for you.

Increase your productivity

Lower your costs through savings in fuel, working time and operating materials (seeds, fertilizer, pesticides). The constant use of the full working width reduces implement wear.

You remain fit longer since you can concentrate fully on the implement while the system takes care of the precise steering for you. That allows you to drive faster and working quality remains consistent over the whole day. Even at night or in poor visibility conditions such as fog or dust, you can drive with guaranteed pass-to-pass accuracy.

At the headland always select the row which you can reach in one turning manoeuvre; that shortens turning manoeuvres considerably. Thanks to Auto-Guide, at the end of the day you have a perfectly worked field without overlaps or skips.

Advantages at a glance:

- Prevents overlaps and skips
- Savings in fuel and working time
- Lower costs for operating materials
- Driver stress relief, fatigue-free driving
- Working quality remains consistent around the clock
- Perfect pass-to-pass accuracy even at night and under poor visibility conditions
- Faster turning manoeuvres

Simple operation

Using the colour control terminal, you set an imaginary line with two points. All other settings are made with the terminal. After setting the working width, all further swaths are kept exactly parallel ¹⁾ to this line.

¹⁾ Auto-Guide performance data is dependent on the data from the GPS provider and the chosen correction signal.

	System Standard (VBS)	System Precision (HP)
Correction signal	OmniSTAR VBS	OminSTAR HP
Static accuracy	± 80 cm	± 10 cm
Dynamic accuracy	± 15 - 20 cm	± 5 cm
Applications	cultivation, application of fertilizers and pesticides	drilling, planting, appl. of fertilizers and pesticides

For further information see the special Fendt Auto-Guide brochure



SUPERIOR PRODUCTIVITY AND LOW OPERATING COSTS PER HOUR THANKS TO VARIO

Those who like to compare the actual costs involved in investing in a new tractor, consider the overall costs and the operating costs per hour or hectare. These comprise four factors: utilization and write-off, fuel consumption and servicing costs as well as the resale value. All four criteria result in the overall profitability of the investment.

Vario reduces fuel consumption, increases performance

Over 40% of the total costs in the lifetime of a tractor are for fuel alone.

That makes the economical use of expensive fuel essential. In-field comparison tests at the Nürtingen University clearly show that the Varios with their best consumption of just 195 g/kWh per hectare or hour, consume significantly less fuel than other tractors and accelerate faster too. That pays off in the long run because you offset the initial purchase price with every hour of operation.

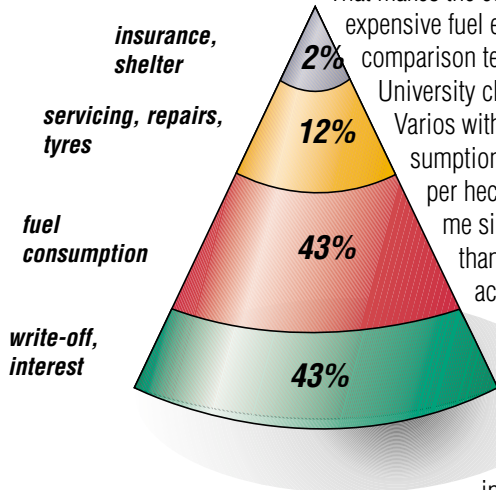

Reduced maintenance costs through long service intervals and integrated diagnostic system

The 900 Vario is designed for long service intervals and reduced oil quantities that need to be changed in the key areas engine, transmission and hydraulics even including the lubricating points. The engine oil needs to be changed every 500 hrs., the transmission oil only every 2000 hours.

Excellent resale value

A further advantage: many operating hours later when you decide to sell your Fendt tractor, you will be delighted to see how it has kept its value. That adds another plus in the overall profitability calculation.

Superior productivity: 2240 handgrips** saved thanks to the joystick

The Variotronic significantly increases

productivity as the neutral profi magazine comparison test 12/99* shows. At the headland, thanks to the ingenious joystick, you save the otherwise necessary constant changing of handgrips between the transmission, hydraulics and PTO's. During cultivation work that makes 2240 handgrips less than the competitors – every day. And the new Headland Management Variotronic™ saves even more time, increases performance and reduces stress on the driver.

Fendt brand quality pays off

Overall profitability is the key benefit of your 900 Vario. The higher price you pay at the start is offset by high performance and low fuel costs during every hour of operation.

*Profi- 12/99 – comparison, cultivation work with seed bed combination and front packer -
** 10 hr. work day, 500 m field length, 160 turning manoeuvres, Fendt driver 1 handgrip x 160 turning manoeuvres; competitor: 15x160 turning manoeuvres = 2400 handgrips



FENDT SERVICE AND SUPPORT

The name Fendt has always been synonymous with trailblazing technology and top quality; today we are also at the forefront in providing first-class service and support for tractor and driver. We offer the customer maximum profitability and competitiveness in an active market place. True to our motto: «Move ahead with us».

FENDIAS for first-class workshop and service quality.

The state of the art mobile diagnostic system FENDIAS, used by FENDT sales agents, helps to increase the number of operating hours by reducing down-times caused by time-consuming fault finding. All faults are automatically stored, and can be called in by the mobile Fendt sales agent on his laptop computer. This saves time and money.

Spare parts with Fendt Night Express Service

An essential part of the first-class service quality of every Fendt sales partner is the electronic parts catalogue FENDOS, which makes rapid, accurate ordering and no-delay delivery of Fendt-original spare parts and accessories possible. If ordered by evening, your Fendt sales partner will have the spare part by 7 a.m. the following morning thanks to the Fendt Night Express Service.

Consultation:

the way to a tailor-made Fendt

Fendt sales agents are experienced specialists who will give extensive advice and information on technology, equipment and the overall profitability of a Fendt tractor.

A trial run in the field – experience the difference

You cannot pass judgement on a Fendt tractor without the experience of driving one in the field! Fendt tractors enjoy a first-class reputation for superb driving and working comfort. Not until you have driven a Fendt, do you realize how big the difference really is when compared with other tractors.



TECHNICAL SPECIFICATIONS

Dimensions

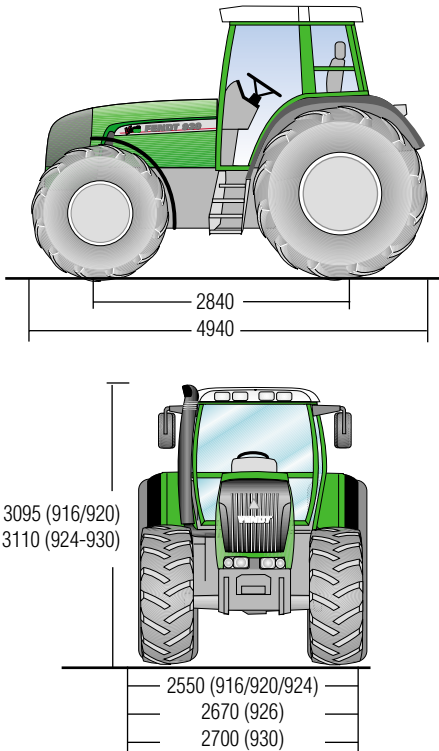

Engine

Rated power (kW/HP) (ECE R24)
 Max. power (kW/HP) (ECE R24)
 Rated power (kW/HP) (EG 97/68)
 Max. power (kW/HP) (EG 97/68)
 No. of cylinders / cooling
 Aspiration / engine control
 Bore / stroke (mm) / displacement (cm³)
 Rated engine speed (rpm)
 Engine speed at max. power (rpm)
 Max. torque (Nm/rpm)
 Torque rise (%)
 Optim. fuel consumption (g/kWh)
 Fuel tank (l)
 Oil change interval (operating hrs.)

Transmission and PTO

Type
 Travel ranges: Field (forward / reverse)
 Road (forward / reverse)
 Top speed (km/h)
 Heckzapfwelle (rpm)
 Front PTO¹⁾

Hydraulics

Type
 Hydraulic pump capacity (l/min)
 Working pressure (bar)
 Rear power lift control
 Additional valves max. (standard) incl. front position control
 Max. lift capacity, rear power lift on the drawbar (kN/kp)
 Max. lift capacity, front power lift (kN/kp)
 Max. available hydraulic oil (l)

Brakes

Rear brakes
 Front brakes

Weights and dimensions

Unladen weight acc.to DIN 70020 (kg)
 Perm. all-up weight (kg)
 Power-weight ratio per HP (kg)
 Payload (kg)
 Max. load on hitch (kg)
 Overall length (mm)
 Overall width (mm)
 Overall height (mm)
 Ground clearance (mm)
 Wheel base (mm)
 Front track with standard tyres (mm)
 Rear track with standard tyres (mm)
 Min. turning radius (m) / with steering brake (m)

Electrical equipment

Starter (kW)
 Battery (Ah)
 Alternator

Cab

Construction
 Climate control

Fendt 900 Vario ^{TMS}				
916	920	924	926	930
132 / 180	154 / 210	176 / 240	199 / 270	221 / 300
146 / 198 ²⁾	162 / 220 ²⁾	186 / 253 ²⁾	210 / 286 ²⁾	228 / 310
151/205	167/227	192/261	216/294	234/318 ²⁾
155/210	171/232	196/267	220/300	239/325
6 / water / four-valve technology turbocharger / intercooler / EEC				
108/125/6870				
2150	2150	2250	2250	2250
1800-2000	1800-2000	1800-2000	1800-2000	1800-2000
825/1400	960/1400	1045/1400	1180/1400	1280/1400
40	40	40	40	35
195	195	195	195	194
530	530	530	530	530
250/500 ³⁾	250/500 ³⁾	250/500 ³⁾	250/500 ³⁾	250/500 ³⁾
stepless Vario transmission				
0,02 – 32 km/h / 0,02 – 20 km/h				
0,02 – 50 km/h / 0,02 – 38 km/h				
50 ⁴⁾	50 ⁴⁾	50 ⁴⁾	50 ⁴⁾	50 ⁴⁾
750/1000 or 540/1000				
1000				
load sensing				
112	112	117	117	117
200	200	200	200	200
EPC, lower link control, shock load stabilising				
5 da ⁵⁾ (4 da) electr. valves / crossgate lever				
pump with pressure-controlled vol. adj.				
95,5/9734	95,5/9734	108,5/11059	108,5/11059	108,5/11059
50/5100	50/5100	50/5100	50/5100	50/5100
65	65	65	65	65
wet, integrated multi-disc brake				
wet brakes on cardan shaft				
air brakes, spring-loaded hand brake				
8750	8750	8800	8800	8950
14000	14000	14000	14000	14000
44	40	35	31	29
5250	5250	5200	5200	5050
2000	2000	2000	2000	2000
4940	4940	4940	4940	4940
2550	2550	2580	2640	2700
3095	3095	3110	3110	3110
605	605	605	605	605
2840	2840	2840	2840	2840
2000	2000	2000	2000	2000
1970	1970	1970	1970	1970
5,9 / 5,4	5,9 / 5,4	5,9 / 5,4	5,9 / 5,4	5,9 / 5,4
4,0				
12 / 2 x 90				
2520 W / 14V / 2 x 90 A				
integrated, sound-proofed, sprung safety cell for the driver, tiltable ventilation system with blower in roof hot water system with 3-speed fan hinged front, side and rear windows air conditioning (standard)				

¹⁾ = upon request, ²⁾ = can be operated as single-acting, ³⁾ = SHPD-Oil, ⁴⁾ = depending on country, ⁵⁾ = applicable power rating for registration

Tyres

	916		920		924		926		930	
	front	rear	front	rear	front	rear	front	rear	front	rear
Standard	480/70 R 34	580/70 R 42	480/70 R 34	580/70 R 42	540/65R34	650/65R42	600/65 R 34	650/85R38	600/65R34	710/70R42
Optional (916 - 930)			front				rear			
			480/70R34 / 540/65R34 / 600/70R30				620/70R42 ¹⁾ 650/65R42 650/75R38 ¹⁾ 710/70R38 710/70R42 650/85R38 900/50R42			
			520/70R34 / 600/65R34							
			600/70R30							

¹⁾ = only for 916 and 920

Standard and optional equipment

	916 Vario	920 Vario	924 Vario	926 Vario	930 Vario
Cab					
Cab suspension	■	■	■	■	■
Armrest-integrated joystick control	■	■	■	■	■
Varioterminal for fine adjustments	■	■	■	■	■
Variotronic Implement Control (Elec. Power Package)	■	■	■	■	■
Variotronic™ Headland Management System	■	■	■	■	■
Camera to the Varioterminal	□	□	□	□	□
Height and tilt adjustable steering column	■	■	■	■	■
Comfort Seat, airm suspension with back rest extension, swivelling, lumbar support	■	■	■	■	■
Super Comfort Seat with heating,	■	■	■	■	■
Radio mounting kit with two speakers	■	■	■	■	■
Tinted windows	■	■	■	■	■
Roof hatch	■	■	■	■	■
Hot water heater with 3-speed fan	■	■	■	■	■
Ventilation with fan in roof	■	■	■	■	■
Air conditioning	■	■	■	■	■
Windscreen washers with intermittent wipe	■	■	■	■	■
Rear window wash/wipe	■	■	■	■	■
External mirrors with mech. width adjustment	■	■	■	■	■
Working lamps front (twin-power)	■	■	■	■	■
Halogen-H4 add. lamps at front	■	■	■	■	■
Working lamps rear (twin-power)	■	■	■	■	■
Xenon working lamps front, A-pillar	□	□	□	□	□
Xenon working lamps rear, mudguard	□	□	□	□	□
Engine control					
Electronic Engine Control	■	■	■	■	■
Turbocharger	■	■	■	■	■
Intercooler	■	■	■	■	■
Cold-start facility	■	■	■	■	■
Engine preheater	□	□	□	□	□
Exhaust brake	□	□	□	□	□
Visco fan	■	■	■	■	■
Strata® air filter	■	■	■	■	■
Transmission					
Stepless Vario transmission	■	■	■	■	■
Vario TMS - engine-transmission management	■	■	■	■	■
Tempomat, automatic maximum output control	■	■	■	■	■
50 km/h top speed ¹⁾	■	■	■	■	■
Safety features					
Four-wheel braking system	■	■	■	■	■
Compressed air system	■	■	■	■	■
Front-axle suspension with levelling control	■	■	■	■	■
Shockload stabilizing system EPC-C	■	■	■	■	■
AWD / differential locks					
Central all-wheel drive, maintenance free	■	■	■	■	■
Comfort control for AWD / differential locks	■	■	■	■	■
Front differential with 100% disc locking	■	■	■	■	■
Power shift PTO's					
Rear: 750/1000 rpm	■	■	■	■	■
Rear: 540/1000 rpm	□	□	□	□	□
Front: 1000 rpm	□	□	□	□	□
Comfort controls PTO, electrohydr. preselection	■	■	■	■	■
External controls for rear PTO	■	■	■	■	■
Hydraulic system					
Axial piston pump	■	■	■	■	■
Electrohydraulic power lift (EPC-C)	■	■	■	■	■
External controls for rear power lift	■	■	■	■	■
External load-sensing connection	□	□	□	□	□
Hydraulic top link	□	□	□	□	□
Quick coupler linkage	■	■	■	■	■
Crossgate lever / joystick	■	■	■	■	■
Down-force hydraulics	■	■	■	■	■
Front power lift	■	■	■	■	■
EPC front power lift with position control	□	□	□	□	□
External controls for front power lift ²⁾	■	■	■	■	■
Additional equipment					
Automatic hitch at rear	■	■	■	■	■
Pickup hitch	□	□	□	□	□
Swinging drawbar	□	□	□	□	□
Reverse travel facility	□	□	□	□	□
Front weights, rear axle weights	□	□	□	□	□
Twin tyres front and rear	□	□	□	□	□
Stub axle at rear	-	-	□	□	□

Engine characteristics

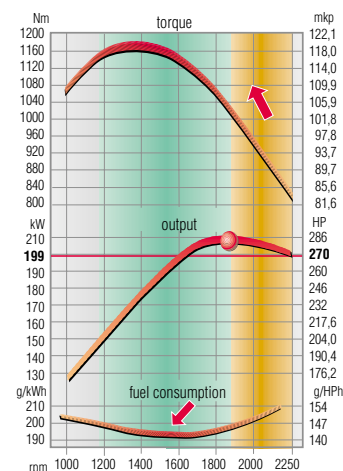
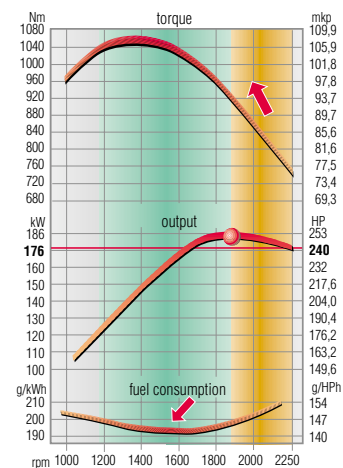
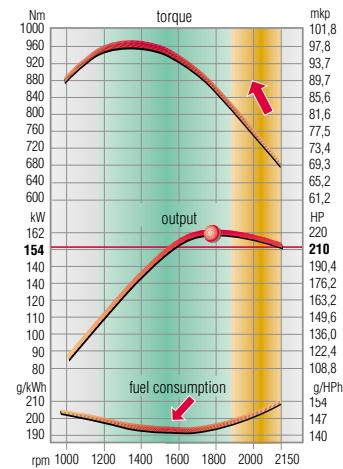
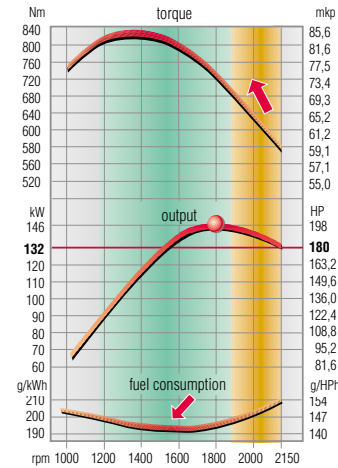

916 Vario
40% torque rise
18 HP extra power

920 Vario
40% torque rise
10 HP extra power

924 Vario
40% torque rise
13 HP extra power

926 Vario
40% torque rise
16 HP extra power

All data regarding delivery, appearance, performance, dimensions and weight, fuel consumption and running costs of the vehicles, correspond with the latest information available at the time of going to press. Changes may be made before the time of purchase. Your Fendt dealer will be pleased to supply you with up-to-date information.

¹⁾ = depends on country regulations, ²⁾ if EPC front power lift fitted

UNPARALLELLED EXPERIENCE

No question about it, the revolutionary Fendt Vario technology has established itself all over Europe. Since 1996, over 30,000 farmers and agricultural contract companies have chosen the revolutionary Fendt Vario drive technology. That gives you reliability and assurance that you have made the right choice.



Sales Agent:



AGCO GmbH
Fendt Marketing
D-87616 Marktoberdorf
Fax (0) 8342 / 77-220
www.fendt.com